

Disconnect Switch, 24 VDC Sentinel Systems



Effective: August 2014

K-83-217

FEATURES

- *Rugged Plastic Housing*
- *Includes Wiring Harness*
- *10 Amp*
- *Meets SAE J1455 & J1113 Standards*
- *24 VDC ONLY*

DESCRIPTION

The Electronic Low Voltage Disconnect Switch, P/N 83-132400-324, is a 10A electronic disconnect switch for use with the Sentinel system. The Disconnect Switch is housed in a rugged plastic housing, and sealed to IP-67 standards. The Disconnect Switch also includes an overcurrent protection system.

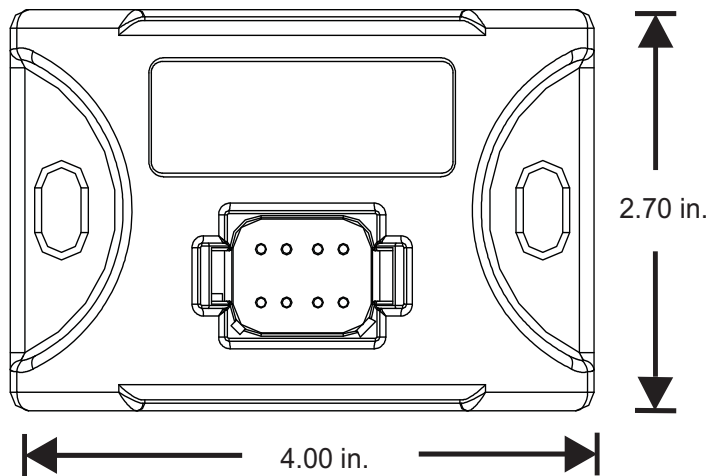

ORDERING INFORMATION

The Disconnect Switch part numbers are provided below.

Part Number	Description
83-132400-324	Disconnect Switch, Electronic Low Voltage for 24VDC ONLY Systems

TECHNICAL DATA

Cutoff Voltage: 10.0V

Restore Voltage: 17.0V

Time to Restore: 10 seconds

This literature is provided for informational purposes only. KIDDE-FENWAL, INC. assumes no responsibility for the product's suitability for a particular application. The product must be properly applied to work correctly. If you need more information on this product, or if you have a particular problem or question, contact KIDDE-FENWAL, Inc.

Kidde is a registered trademark of Kidde-Fenwal Inc. All other trademarks are the property of their respective owners.