

# AUTROFLAME IR FLAME DETECTOR BG-201

## Interactive fire detection systems Product Datasheet

### Features

- Interactive
- Different sensitivity settings possible
- Short circuit isolator in each detector
- Comprises a built-in alarm indicator (LED)
- Automatic addressing
- Solar resistant
- Very fast fire detection
- Not blinded by oil film on window
- High degree of immunity to false alarm sources
- EN54-10, EN54-17 approved
- Designed to meet the requirement of the major maritime classification societies

### Description / Application

BG-201 is a point flame detector for detection of fires involving combustion of carbonaceous materials.

The detector has a high IP rating making it suitable for the harshest environments.

Performance class can be configured by the AutoSafe/Autroprime system according to table 1.

The advanced signal processing and DYFI+ intelligence ensure that the detector has a high immunity to any nuisance alarm source combined with fast detection of real fires. This makes the BG-201 detector the obvious choice for demanding applications such as a ship's engine room.

Note:

Accumulation of water, ice, snow or other pollution on the sensor window may affect the sensitivity of the detector. In order to maintain the detection range (table 1) the glass must be cleaned regularly.

### Principle



Two infrared sensors detect the infrared spectrum from a fire. The sensors evaluate different parts of the infrared spectrum using this information to verify that the signals correspond to the characteristics of a real flame.



Technical specifications	
Weight	210 g
Materials	Polycarbonate, sapphire glass
Colour	Transparent / light grey
Sensitivity	Ref. Table 1
Field of view	Horizontal=+/-45°, Vertical=+30°/ -45° (see the Field of view diagram below for additional EN 54-10 information)
Voltage:	Supplied from detector loop
Current consumption: Stand by Current consumption: Alarm LED on	90 µA 2,1 mA
CPD certificate	0832-CPD-1999
Degree of protection	IP66 and 67
Working temperature	-40 to +70°C
Storage temperature	-50 to +70°C
Humidity	0-96 % rh, can withstand 100% condensing humidity for short periods of time
Maintenance	Cleaning of window
Service	Replace if faulty
Cable size	Maximum cable 2,5 mm <sup>2</sup> / AWG14
Approvals	See website

Table 1 - Performance classes (EN 54/10)	
Performance class	Range
Class 1	Up to 25 m
Class 2*	Up to 17 m
Class 3	Up to 12 m

\*In Legacy mode only class 2 is available

Table 2 – Mode selection	
Mode selection, cutting of jumper J4 on PCB	J4
STANDARD: AutroSafe / Autroprime mode	
LEGACY: FDI compatible mode	

Product Name	Part number	Description
BG-201	116-BG-201	AutroFlame IR flame detector
BG-201F	116-KITD-BG-201F	Facade security BG-201

### Dimension Drawing (mm)

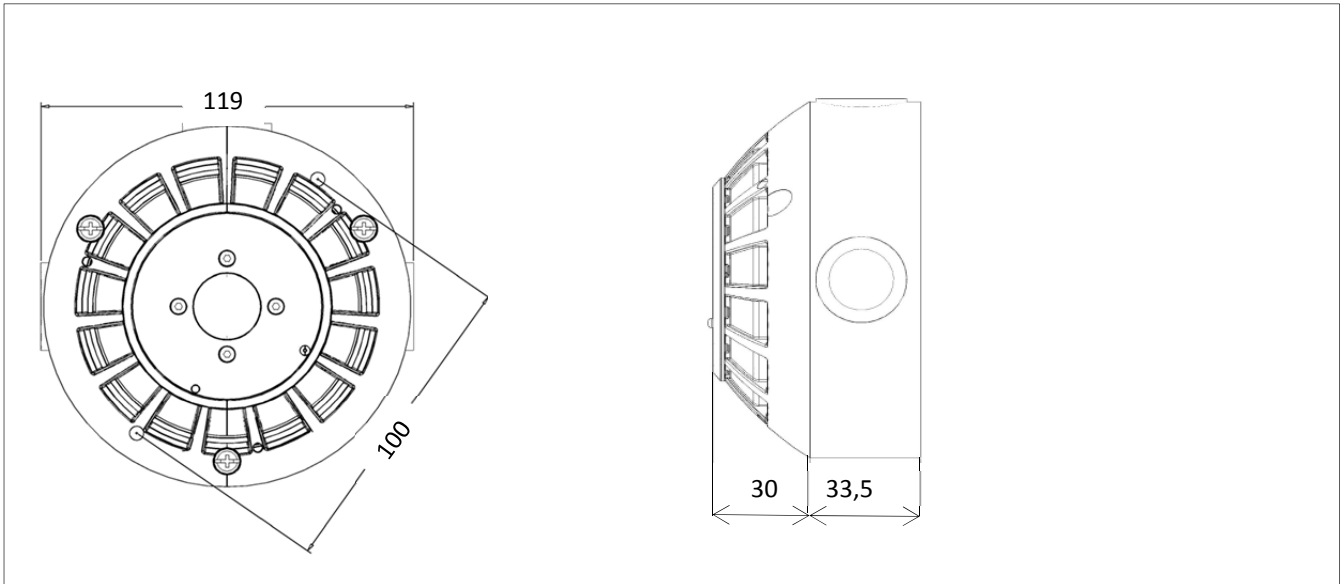

### Connection AI\_Com loop

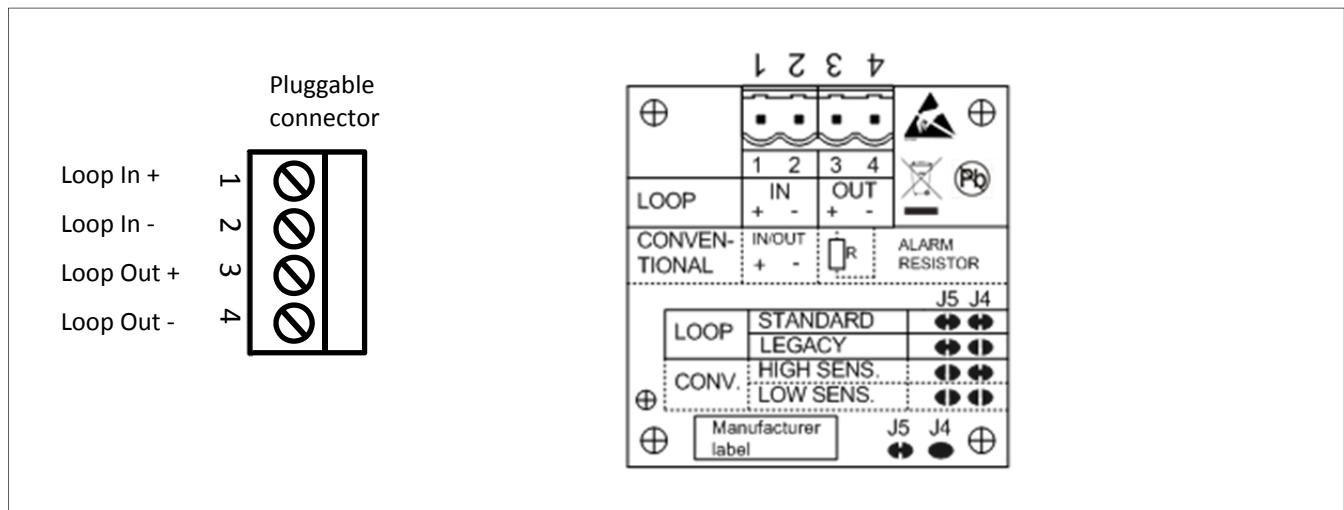

### Field of view

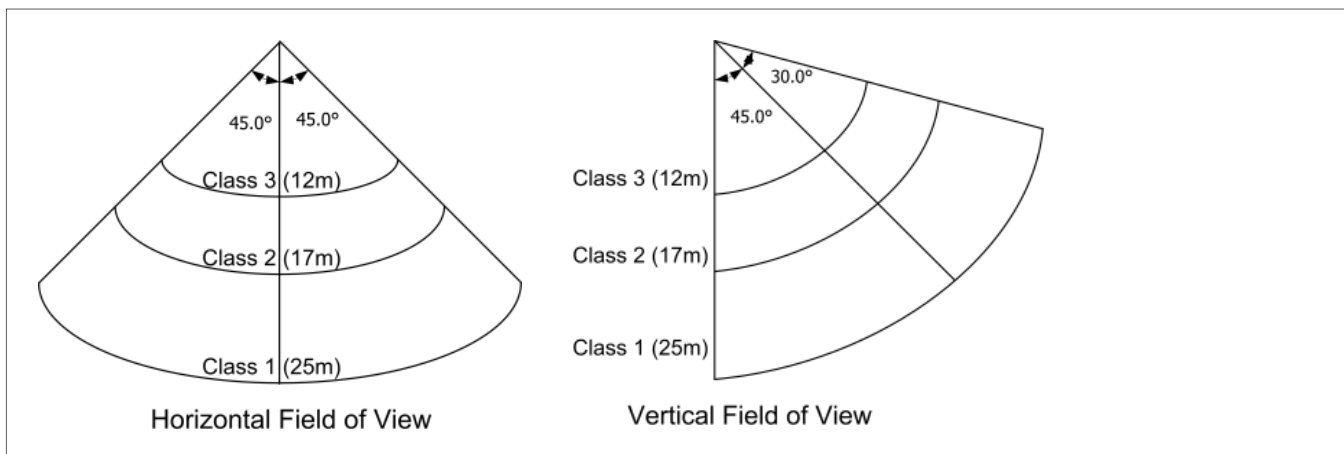

To comply with the directional dependence requirements for EN 54-10:2002 an angle of  $\pm 30^\circ$  from  $0^\circ$  ( $0^\circ$  = Orientation of detector in same axes as flame source) should not be exceeded, based on lab testing at a distance of approximately 5.0 ft (1.5 m).